



Model Specifications

The EcoSmart™ Burner is the core product of all EcoSmart™ Fires, being the chamber that houses the fuel. It offers ultimate flexibility due to its modular design which presents you with the opportunity to create an open fire just about anywhere! The EcoSmart™ Burner can be installed into any setting that complies with our Compulsory Installation and Clearance Specifications.

Fuel	Use Denatured Ethanol only. Refer to www.ecosmartfire.com for commercially available fuel names around the world.
Design Features	<p>Sophistication, elegance, cutting-edge performance and functionality define the new XL Burner, which has been developed in response to overwhelming demand. A popular trend amongst designers and architects has been to join several EcoSmart™ Fire burners in line to form an elongated flame, creating a stunning centrepiece for use in both residential and commercial premises. The XL Burner includes baffles (for fuel efficiency), drafters (for flame stability), smart filling point, and a new design shut-off mechanism. As with all EcoSmart™ Fire products, safety aspects have been thoroughly considered and implemented.</p> <p>The XL Burner is designed for installation in commercial premises including offices, bars and restaurants as well as units, apartments and houses.</p>

Construction Detail	<p>The EcoSmart™ XL Burner is made from Stainless Steel (Grade 304).</p> <p>Outline of Burner features:</p> <ol style="list-style-type: none"> Filling Point comprising of 2 parts: <ol style="list-style-type: none"> Spring Loaded Cap - separated from burning/ignition zone Filling Box - engineered so that the jerry can spout is fully enclosed prior to releasing the fuel supply, thus allowing filling at a high rate, whilst eliminating splashing as the fuel is being decanted Swivel ring – the accompanying lighting rod is inserted into this swivel ring to control the flip lid system. Flip lid shut off system - The lid flips across the ignition zone which extinguishes the flame. When open it also blocks access to the filling point acting as a deterrent to filling the burner whilst in operation. Volume/Setting Markings - enable you to determine fuel required / available. Ignition point - the burner is best ignited from the right hand side of the ignition zone. Top Tray - The custom built Top Tray supplied with this model is made from Stainless Steel (Grade 304). It is designed to sit underneath the burner without being seen from above. The Top Tray is a compulsory accessory to guard against heat transference and to collect any accidental spillage. Spacers - There are “spacers” fitted on all exterior panels and a “spacer” bar that separates the base of the burner from the surrounding materials. This prevents any heat transference and enforces compulsory clearances.
----------------------------	---

The EcoSmart™ Burner is manufactured in Australia by an ISO9001:2000 accredited manufacturer.

Accompanying Compulsory Accessories	The XL Burner Kit is accompanied by an operational system that ensures the safety of the product. Every aspect from decanting the fuel, lighting the flame, regulating the flame to extinguishing the flame, has been thought through and accessorised in order to control the method of operation.
--	---

All models come with a Top Tray, Lighter, Jerry Can, Lighting Rod and Manual.



Recommended Accessories Fire Extinguisher, EcoSmart™ Fire Screen, Burner Cover.

Model Specifications

Clearances

INSERTING WITHIN A FIREBOX SETTING:

The EcoSmart™ XL Burner can only be fitted into a non-combustible firebox that has minimum clearances of W 1100mm [43.3in] x H 500mm [19.7in] x D 500mm [19.7in].

Custom made fireboxes must:

- Be made out of a non-combustible material such as stainless steel
- Be constructed to accommodate a Top Tray or "Twin Skin"
- Have built in spacers of 20mm [0.8in] on all sides to ensure that it does not sit directly against any combustible materials and an air gap is incorporated for insulation around the box construction

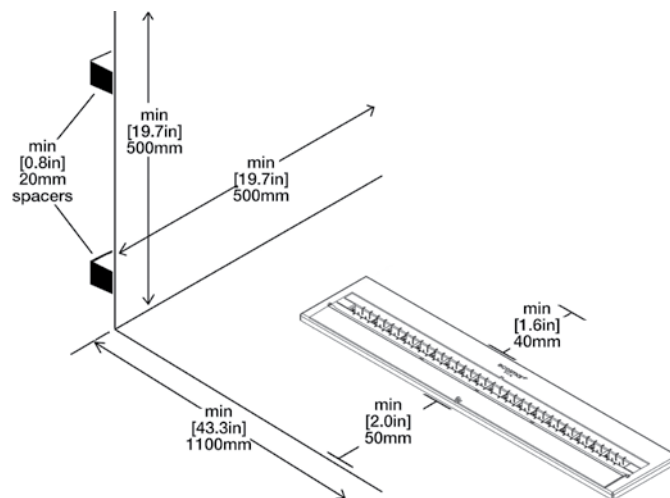

INSERTING WITHOUT A FIREBOX SETTING:

REAR: A minimum of 40mm [1.6in] space between the burner edge/Top Tray edge and the rear wall (which should be a non combustible material).

FRONT: A minimum of 65mm [2.6in] space between the burner and the front edge.

OVERHEAD: A minimum clearance of 1500mm [59.1in] from the burner mouth to the nearest combustible.

SIDES: A minimum clearance of 600mm [23.6in] from the burner edge to the nearest combustible.

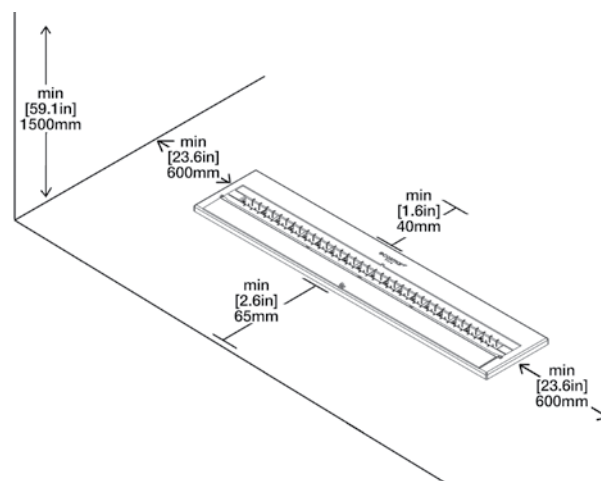

Model Specifications

Clearances

CONVERTING AN EXISTING FIREPLACE:

In order to keep the heat from escaping through the flue, place a panel of non-combustible heat reflective material such as stainless steel across your flue opening or utilise the damper within the existing fireplace setting to conserve heat.

All settings must incorporate a "Twin Skin". If using the Top Tray that has been supplied with this model, the cut out dimensions are H 123mm [4.84] x W 888mm [34.96] x D 173mm [6.81].

Multiple burners may be installed into a fireplace setting however the ventilation requirements must be adhered to at all times. It is imperative that when installing multiple burners you consider strongly the impact of any accident and minimise it wherever possible.

A fire extinguisher is a compulsory accessory.

Installation Requirements

There are many different variations available for installing the EcoSmart™ XL Burner. In all cases, the EcoSmart™ XL Burner must:

- Be installed into non-combustible material ONLY – for example stainless steel, concrete, brick, stone
- Be fitted within a "Twin Skin", such as the Top Tray included with this model from The Fire Company Pty Ltd so that there is a second barrier to capture any accidental spillage. If the Twin Skin is not supplied by The Fire Company Pty Ltd then it must undergo a "water tight" test prior to inserting the EcoSmart™ Burner into place
- All gas connections or pipelines near your EcoSmart™ installation must be disconnected and made safe by an appropriately qualified professional prior to installation
- Be installed into a fixed and secure position before filling, lighting and operating
- Be installed in a position that limits relocation requirements to eliminate the risk of accidents caused by fuel spillage – they are not designed to be relocated frequently
- Be installed into a level platform
- DO NOT INSTALL DIRECTLY BESIDE OR NEAR WALLPAPER, LAMINATE, VENEER OR ANY SURFACE THAT HAS NOT BEEN FIRE RATED (the heat will impact the material, and in some circumstances the glue used for its application). THIS INCLUDES THE DETAILING/FINISHING MATERIALS USED ON THE DECORATIVE SURFACES AROUND THE INSTALLED FIREBOX.
- Be installed into a setting that has a square back – the incorporation of angled backs alters the aerodynamics of the flame environment and could lead to an unstable flame behaviour

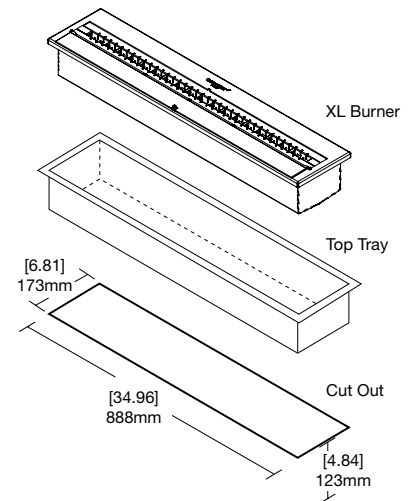

As a general guide we recommend that:

- Any furniture items or fittings directly above or beside the EcoSmart™ Fire installation be deemed suitable for heat tolerances by their manufacturer e.g Plasma Screens
- A heat reflective panel made of non combustible material (ideally stainless steel) be installed as the surround and top of the fireplace setting to assist in heat distribution
- Any reconstituted materials you wish to use be checked in terms of strength and suitability around such high temperature variations as some materials will crack – call The Fire Company Pty Ltd for more information about specific surfaces
- Glass or mirrored surfaces near the EcoSmart™ Fire installation must be toughened

SPACERS: When the XL Burner is in position, there is usually an air gap around it. Do not pack with insulation or other materials, as the air spacers are required for ventilation.

Model Specifications

Ventilation

EcoSmart™ Fires do not require any form of permanent fixture or fitting, such as a flue for ventilation, a permanent gas connection or any kind of fixed utility for fuel supply.

Denatured Ethanol* is safe to burn indoors without venting, because its main by-products are carbon dioxide, water steam and heat.

In a house of typical construction, that is, one that is not of unusually tight construction due to heavy insulation and tight seals against air infiltration, an adequate supply of air for combustion and ventilation is provided through infiltration. However, if the heater is used in a small room where less than 5.7m³ [200ft³] of air space is provided for each 1000 BTU per hour of heater rating (considering the maximum setting), the door(s) to adjacent room(s) should be kept open or a window to the outside should be opened at least 25.4mm [1in] to guard against potential build up of indoor air pollution. Do not install or operate in a bathroom or any other small room.

The room cannot be less than 30m³ [1059.44ft³] per burner.

Efficiency

The EcoSmart™ Fire is efficient because it is flueless which means all the heat stays in the room rather than most of it being flued outside as residual emissions.

You can turn the burner on and off as desired, this allows you to control the amount of heat being generated and the quantity of Denatured Ethanol* used.

Thermal Output Net	5 Litres: 9.35 Mj/h – 8,871 BTU – 2.6 Kw/h 10 Litres: 10.34 Mj/h – 9,793 BTU – 2.87 Kw/h
Fuel Type	Denatured Ethanol Some fuels are better than others, it's important to source information on the best fuel in your area from your local retailer/distributor. Visit www.ecosmartfire.com to find out what Denatured Ethanol is called around the world.
Thermal Efficiency	Over 90%
Heats on Average	Over 25m ² OR 269ft ²
Fuel Consumption	5 Litres: 0.47 Ltr/hr OR 0.12 Gal/hr 10 Litres: 0.50 Ltr/hr OR 0.13 Gal/hr In general 5 Litres OR 1¼ Gal of fuel would last over 10 hours and 10 Litres burns for around 19 hours.
Volume Capacity	10 Litres / 2 ¾ Gal

These values are indicative only and may vary depending on the model purchased and installation.

NOTE: When the XL Burner reaches 2 Litres of fuel, the flame becomes progressively smaller and burns for longer.

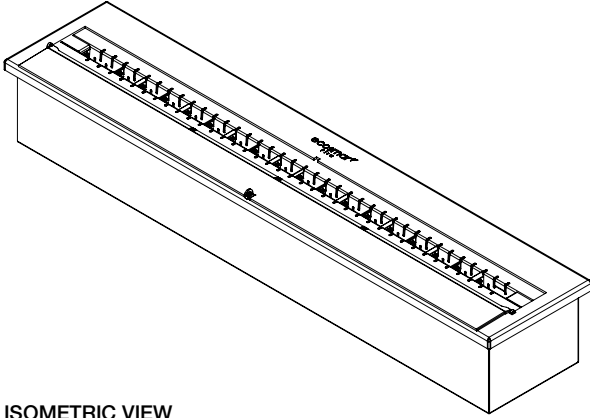

ISOMETRIC VIEW

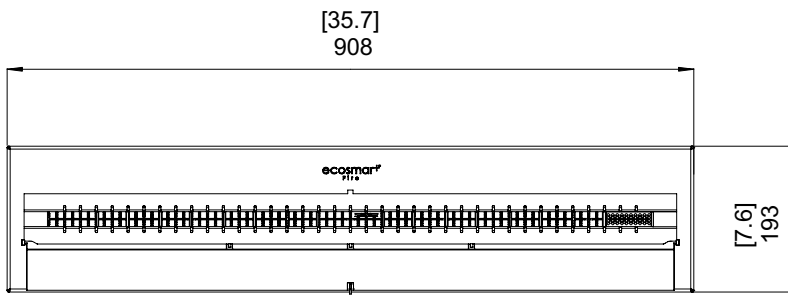

TOP VIEW

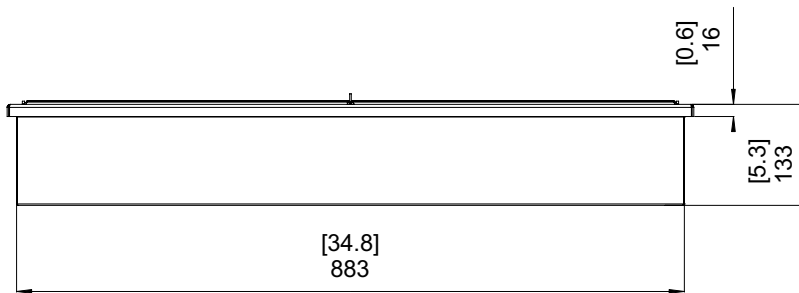

FRONT VIEW

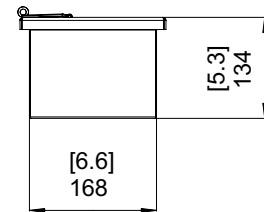

SIDE VIEW

Measurements

[inches] = imperial
mm = metric

Weight

18.7kg, 41.3lbs

Materials

Brushed Stainless Steel

Scale 1:10



Conditions of Use

1. For the purposes of this model specification we refer to the fuel used in the EcoSmart™ Fire as **Denatured Ethanol***.

***There are many different names for this fuel around the world. Please refer to www.ecosmartfire.com for a list of commercially available fuel names in your country.**

Denatured Ethanol* is classified as a Dangerous Goods Flammable Liquid Class 3, PGII and is regulated by specific standards and rules. You must familiarise yourself with the appropriate regulations of

your country in order to safely and legally store, handle, decant and use this fuel.

The customer warrants to The Fire Company Pty Ltd that after delivery of their EcoSmart™ Fire and whilst The Fire Company Pty Ltd retains any interest in the goods or consigned goods (as the case may be) the customer shall comply with all applicable Acts, Regulations and Laws dealing with the transport, unloading and storage of Dangerous Goods.

2. Children do not recognize the dangers that can arise when handling Dangerous Goods,

nor do they recognize the volatility of flammable liquids when ignited. Please ensure you keep children at a safe distance and supervised at all times when operating the fire.

3. Approval from building authorities may be required. Please ensure you contact the appropriate parties before installing your EcoSmart™ Fire.

4. It is a condition of purchase that you obtain a fire extinguisher Ammonium Phosphate AB:E type. These can be purchased from your distributor or independently.

Warnings

1. Risk of explosion:

- a) Never use any fuel other than the fuels specifically identified for use in the appliance. Never use gasoline.
- b) Never fill the fuel reservoir when it is operating or still hot.
- c) Never fill fuel reservoir in areas where flammable vapours or gas may be present.
- d) Never store or transport the fuel in other than a metal or plastic container that is:
 1. Acceptable for use with the specific fuel.
 2. Is in the original container for the alcohol fuel.

2. Never store fuel in the living space where the fire is situated.

3. Due to high surface temperatures, keep children, pets, clothing, and furniture away. The unit is hot while in operation, contact with the EcoSmart™ Fire may cause skin burns.

4. Risk of indoor air pollution – use EcoSmart™ Fires only in well-ventilated areas. People with breathing problems should consult a physician before using the appliance.

5. Do not use the EcoSmart™ Fire to heat or boil water or as a cooking appliance. Do

not throw waste materials or paper into the EcoSmart™ Fire.

6. EcoSmart™ Fires have not been tested with an unvented gas log set. To reduce the risk of fire or injury, do not install an unvented gas log set into this appliance.

7. The EcoSmart™ Fire has not been tested for use with doors. To reduce the risk of fire or injury, do not install doors.

8. It is recommended that the EcoSmart™ Fire be fixed into position to avoid displacement as per instruction provided with each model.

9. Do not dismantle the EcoSmart™ Burner.

10. Do not attach any other tank to the EcoSmart™ Burner.

11. EcoSmart™ Fires must only be operated using authorised accessories & equipment.

12. Do not obstruct the open/close sliding mechanism of the EcoSmart™ Burner in any way as this could result in the jamming/non functionality of the shut off mechanism.

13. The EcoSmart™ Burner should not be started if a fault is suspected or when there appears to be any damage to the burner or its housing.

14. The use of any fitting other than those available from or recommended by The Fire Company Pty Ltd for the EcoSmart™ Firebox and Burner is not permitted.

15. The Fire Company Pty Ltd does not accept responsibility for any damage which occurs if the EcoSmart™ Fire is used for purposes other than those for which it is intended, or if it is incorrectly operated or repaired by unqualified persons.

16. The EcoSmart™ Fire is not intended to operate continuously. To avoid heat expansion and potential splitting of the timber framework in Designer Range models please ensure that the model is allowed to cool down completely on a regular basis.

If you have any questions regarding any of the above important safety information please contact your distributor or The Fire Company Pty Ltd.

Testing & Compliance

Models from the EcoSmart™ Fire Collection have achieved the following certification and approvals:



The EcoSmart™ Fire is manufactured by The Fire Company Pty Ltd whose quality management system is certified as being in conformity with ISO 9001:2000.



The EcoSmart™ Fire is the first product of its kind to have its collection so comprehensively UL/ULC listed. For the most up to date list of UL/ULC Listed models and compliance requirements please contact your local distributor.

Instructions and specifications for the EcoSmart™ Fire were tested as far as practicable to a selection of clauses from AS4553/AG103 – Australian Standard for Gas Space Heaters (closest comparable product at the time of invention)

Investigation into applicable standards and testing platforms for compliance to GS & CE were held and The Fire Company has gained a Compliance Verification Declaration from Globalnorm GmbH.



The EcoSmart™ Fire Collection has achieved Swedish Institute for Technical Approval in Construction (SITAC) approval.